

Use safety stand adapter as shown for stable support.

Attachment  
SST No. LM4519-0000

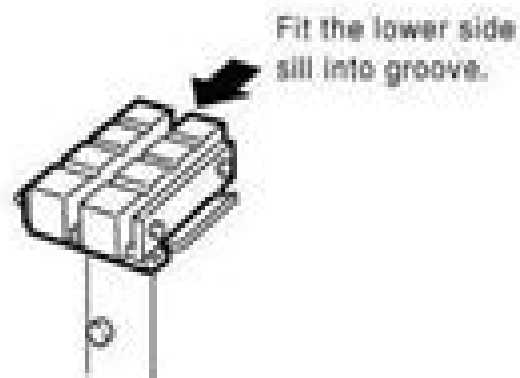
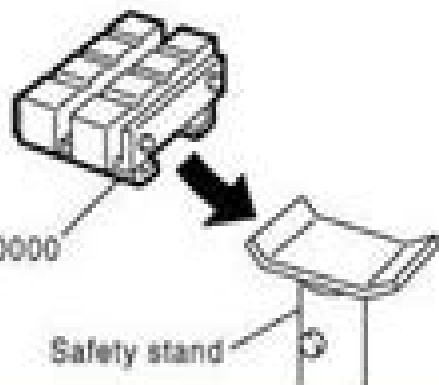

# 08 Ford Focus S Guide

**Patrick R. Delaney, Ray Whittington**



## **08 Ford Focus S Guide:**

*Fuel Economy Guide*, Fuel Economy Guide, 2001 **Wiley CPA Examination Review 2007-2008, Outlines and Study Guides** Patrick R. Delaney, Ray Whittington, 2007-06-11 Wiley CPA Exam review 34th Edition 2007 2008 Volume 1 Outlines and Study Guides Covers all four sections of the CPA examination point by point Stresses important topical areas to study for each part Helps establish a self study preparation program Divides exam into 45 manageable study units Provides an outline format supplemented by brief examples and illustrations Makes material easy to read understand and remember Includes timely up to the minute coverage for the computerized exam Explains step by step examples of the solutions approach Contains all current AICPA content requirements for all four sections of the exam Volume 2 Problems and Solutions Offers selected problems from all four examination sections Contains rationale for correct or incorrect multiple choice answers Covers the new simulation style problems offering more than 75 practice questions Details a solutions approach to each problem Updates unofficial answers to reflect current laws and standards Groups multiple choice questions into topical categories within modules for easy cross referencing Provides a sample examination for each of the four exam parts The computer based CPA exam is here Are you ready The 34th Edition of the Wiley CPA Exam Review is revised and updated for the new computerized exam containing AICPA sample test questions released as recently as April 2007 To help candidates prepare for the new exam format this edition includes a substantial number of the new simulation type questions Passing the CPA exam on your first attempt is possible We d like to help Get Even More Information Online You ll find a wide range of aids for doing your best on the CPA exam at wiley com cpa including content updates CPA exam study and test taking tips and more All Wiley CPA Exam Review products are listed on the site *Insider Guide to Easy Car Buying: Spend a Tenner Save a Grand* Tony Willard, **The Principal's Guide to Managing School Personnel** Richard D. Sorenson, Lloyd M. Goldsmith, 2008-11-10 An excellent tool for aspiring principals as well as those who find it uplifting to be reassured that they are doing the right thing Gerard Dery Principal Nessacus Regional Middle School Dalton MA This book serves as a valuable tool for districts seeking to enhance the skill level of their principals and would be ideal for professional development Carolyn Banks Regional Director of Teacher Education University of La Verne A comprehensive guide to building successful relationships with all school personnel Inspiring faculty and support staff to perform their best is a key factor in developing a school culture that helps students thrive This resource provides principals with the policies procedures and techniques to lead and manage school personnel and create an effective work environment The authors provide real world scenarios and practical strategies to help define the principal s leadership role and strengthen personnel management skills The book also offers reflective exercises in each chapter to assist administrators in evaluating their own schools and practices Based on ISLLC and ELCC standards for school leadership this book covers Shaping school culture to promote shared ownership of the school s vision Recruiting selecting and retaining qualified personnel Effective communication and conflict resolution

Handling challenging situations such as supervising marginal employees and addressing grievances The Principal's Guide to Managing School Personnel is an indispensable reference for managing one of your school's most important resources your staff

**Handbook of Resilience in Children of War** Chandi Fernando, Michel Ferrari, 2013-04-23 Their frightened angry faces are grim reminders of the reach of war They are millions of children orphaned displaced forced to flee or to fight And just as they have myriad possibilities for trauma their lives also hold great potential for recovery The Handbook of Resilience in Children of War explores these critical phenomena at the theoretical research and treatment levels beginning with the psychosocial effects of exposure to war Narratives of young people's lives in war zones as diverse as Afghanistan Sri Lanka Columbia and Sudan reveal the complexities of their experiences and the meanings they attach to them providing valuable keys to their rehabilitation Other chapters identify strengths and limitations of current interventions and of constructs of resilience as applied to youth affected by war Throughout this cutting edge volume the emphasis is on improving the field through more relevant research and accurate evidence based interventions in such areas as An ecological resilience approach to promoting mental health in children of war Child soldiers and the myth of the ticking time bomb The Child Friendly Spaces postwar intervention program The role of education for war zone immigrant and refugee students Political violence identity and adjustment in children The Handbook of Resilience in Children of War is essential reading for researchers scientist practitioners and graduate students in diverse fields including clinical child school and developmental psychology child and adolescent psychiatry social work counseling education and allied medical and public health disciplines

**The Report: Malaysia 2008 - Oxford Business Group**, 2008

**Springer Handbook of Geographic Information** Wolfgang Kresse, David M. Danko, 2012-02-21 Computer science provides a powerful tool that was virtually unknown three generations ago Some of the classical fields of knowledge are geodesy surveying cartography and geography Electronics have revolutionized geodetic methods Cartography has faced the dominance of the computer that results in simplified cartographic products All three fields make use of basic components such as the Internet and databases The Springer Handbook of Geographic Information is organized in three parts Basics Geographic Information and Applications Some parts of the basics belong to the larger field of computer science However the reader gets a comprehensive view on geographic information because the topics selected from computer science have a close relation to geographic information The Springer Handbook of Geographic Information is written for scientists at universities and industry as well as advanced and PhD students

**VW Polo Petrol & Diesel Service & Repair Manual** R. M. Jex, 2007 Hatchback including special limited editions Does NOT cover features specific to Dune models or facelifted Polo range introduced June 2005 Petrol 1.2 litre 1198cc 3 cyl 1.4 litre 1390cc non FSI 4 cyl Does NOT cover 1.4 litre FSI engines Diesel 1.4 litre 1422cc 3 cyl 1.9 litre 1896cc 4 cyl inc PD TDI turbo

**Routledge Handbook of Sport Expertise** Joseph Baker, Damian Farrow, 2015-03-24 Understanding and developing expertise is an important concern for any researcher or practitioner working in elite or high performance

sport Whether it s identifying talented young athletes or developing methods for integrating cutting edge sport science into daily coaching practice scientists coaches and researchers all need to understand the skills characteristics and knowledge that distinguish the expert performer in sport The Routledge Handbook of Sport Expertise is the first book to offer a comprehensive overview of current research and practice in the emerging field of sports expertise Adopting a multi disciplinary multi faceted approach the book offers in depth discussion of methodological and philosophical issues in sport expertise as well as the characteristics that describe sporting experts and how they can be facilitated and developed Exploring research theory and practice the book also examines how scientists and practitioners can work together to improve the delivery of applied sport science With contributions from many of the world s leading researchers in expertise and skill acquisition in sport the Routledge Handbook of Sport Expertise is important reading for any advanced student researcher coach or sport science support officer looking to better understand this cutting edge topic

**The Oxford Handbook of Positive Organizational Scholarship** Kim S. Cameron,Gretchen M. Spreitzer,2013-05-02 An ideal resource for organizational scholars students practitioners and human resource managers this handbook covers the full spectrum of organizational theories and outcomes that define explain and predict the occurrence causes and consequences of positivity

**Directory of Research Grants 2008** Schoolhouse Partners Llc,2008-05 It was the 50s and life was simple until September 25 1954 That was the night that would be etched in the memory of the citizens of Stanfield Massachusetts The Chief of Police described the brutal savagery of the double homicide as the most atrocious crime in the history of the city A fourteen year old girl and the four year old boy in her care were murdered at the hands of a deranged depraved killer A Thread of Evidence places the reader at the scene of the crime an eye witness to the senseless stabbing of two innocent children With a piece of crochet thread as their only clue the entire police department lead by detectives Steven Logan and Raymond Gage scour the city in search of a maniacal savage When all tips and leads have been exhausted they review all evidence They come back to the thread The only real evidence With tenacity and perseverance of Logan and Gage the killer is apprehended The reader experiences the twists and turns of the investigation and ultimately occupies a reserved seat in the Superior Court as the trial proceedings commence A Thread of Evidence has been written as fiction but inspired by an actual event Fifty years later it remains etched in the minds of all who had lived in the area The author has researched court records newspapers interviewed neighbors police and has drawn on personal recollections of the crime The story has been recounted over and over and to this day it continues to be discussed A Thread of Evidence is a compelling account of superb detective work and unprecedented dedication of an entire police department

**Handbook of Special Education** James M. Kauffman,Daniel P. Hallahan,2011-05-15 Special education is now an established part of public education in the United States by law and by custom However it is still widely misunderstood and continues to be dogged by controversies related to such things as categorization grouping assessment placement funding instruction and a variety of legal issues The purpose of this 13 part

57 chapter handbook is to help profile and bring greater clarity to this sprawling and growing field To ensure consistency across the volume chapter authors review and integrate existing research identify strengths and weaknesses note gaps in the literature and discuss implications for practice and future research Key features include Comprehensive Coverage Fifty seven chapters cover all aspects of special education in the United States including cultural and international comparisons Issues Trends In addition to synthesizing empirical findings and providing a critical analysis of the status and direction of current research chapter authors discuss issues related to practice and reflect on trends in thinking Categorical Chapters In order to provide a comprehensive and comparative treatment of the twelve categorical chapters in section IV chapter authors were asked to follow a consistent outline Definition Causal Factors Identification Behavioral Characteristics Assessment Educational Programming and Trends and Issues Expertise Edited by two of the most accomplished scholars in special education chapter authors include a carefully chosen mixture of established and rising young stars in the field This book is an appropriate reference volume for anyone researchers scholars graduate students practitioners policy makers and parents interested in the state of special education today its research base current issues and practices and future trends It is also appropriate as a textbook for graduate level courses in special education

*Railways, Urban Development and Town Planning in Britain: 1948-2008* Russell Haywood, 2016-03-23 This book provides a critical overview of the relationships between planning and railway management and development during the key period in the 20th Century when the railway was in public ownership 1948-94 It assesses the strength of the relationships when working in collaboration with the private sector The book then focuses on the interplay between planning and railway since privatization in 1994 and points to best practice for the future in institutional structures and policy development to secure improved outcomes

**Living Resources of the Delaware Estuary**, 1995

Lemon-Aid Used Cars and Trucks 2011-2012 Phil Edmonston, 2011-04-25 As Toyota skids into an ocean of problems and uncertainty continues in the U S automotive industry Lemon Aid Used Cars and Trucks 2011-2012 shows buyers how to pick the cheapest and most reliable vehicles from the past 30 years Lemon Aid guides are unlike any other car and truck books on the market Phil Edmonston Canada's automotive Dr Phil for 40 years pulls no punches Like five books in one Lemon Aid Used Cars and Trucks is an expos of car scams and gas consumption lies a do it yourself service manual an independent guide that covers beaters lemons and collectibles an archive of secret service bulletins granting free repairs and a legal primer that even lawyers can't beat Phil delivers the goods on free fixes for Chrysler Ford and GM engine transmission brake and paint defects lets you know about Corvette and Mustang tops that fly off gives the lowdown on Honda Hyundai and Toyota engines and transmissions and provides the latest information on computer module glitches

**Routledge Handbook of Sports Performance Analysis** Tim McGarry, Peter O'Donoghue, Jaime Sampaio, 2013-03-05 Sport performance analysis techniques help coaches athletes and sport scientists develop an objective understanding of actual sport performance as opposed to self report fitness tests or laboratory based

experiments For example contemporary performance analysis enables elite sports people and coaches to obtain live feedback of match statistics and video sequences using flexible internet systems systems that have become an indispensable tool for all those involved in high performance sport The Routledge Handbook of Sports Performance Analysis is the most comprehensive guide to this exciting and dynamic branch of sport science ever to be published The book explores performance analysis across the four main contexts in which it is commonly used support for coaches and athletes the media judging sport contests and academic research It offers an up to date account of methodological advances in PA research assesses the evidence underpinning contemporary theories of sport performance and reviews developments in applied PA across a wide range of sports from soccer to track and field athletics Covering every important aspect of PA including tactics strategy mechanical aspects of technique physical aspects of performance such as work rate coach behaviour and referee behaviour this is an essential reference for any serious student researcher or practitioner working in sport performance analysis sport coaching or high performance sport [Willing's Press Guide and Advertisers' Directory and Handbook](#) ,2002

[Handbook of Gastrointestinal Cancer](#) Janusz A. Z. Jankowski, Ernest Hawk, 2012-10-15 Do you manage patients with gastrointestinal cancer Do you need a rapid reference handbook to guide you through your diagnosis and management options If so then Handbook of Gastrointestinal Cancer is the book for you providing clear practical guidance to the diagnosis and clinical management of all forms of GI cancer in a highly accessible format Perfect for GI Oncology trainees and junior gastroenterologists oncologists and designed for point of care consultation each chapter is structured in a uniform way and contains a variety of handy text features to help the reader such as case histories key practice points key weblinks and potential pitfalls The authors emphasize the best clinical assessment and management methods of patients and dedicate an entire chapter to each cancer from esophageal to lower GI and from biliary to pancreatic cancer This attractive new book features Comprehensive yet quick and easy display of key points Case studies to illustrate cardinal lessons or dilemmas A fully integrated GI oncologic approach An outstanding and international editor and author team of great experience Illustrations of key clinical or investigative features Handbook of Gastrointestinal Cancer answers all your clinical needs and is a must have tool on the ward for all trainee and junior gastroenterologists and oncologists Handbook of GI Cancer does an excellent job of indicating which clinical recommendations are solidly evidence based and highlighting those that would benefit from further research Monica M Bertagnolli MD Chief Division of Surgical Oncology Dana Farber Brigham and Women s Cancer Center Boston USA Handbook of Gastrointestinal Cancer is a comprehensive text that should be on the bookshelf of every physician and surgeon who deals with GI malignancies The editors who are internationally renowned have assembled an all star cast of contributing authors from around the world The inclusion of key points and case studies and the use of an evidence based approach make this a stand out reference Mark K Ferguson MD Professor Department of Surgery and The Cancer Research Center The University of Chicago Medicine Biological Sciences Chicago USA **The Oxford**

**Handbook of School Psychology** Melissa A. Bray, Thomas J. Kehle, 2011-02-18 The Oxford Handbook of School Psychology focuses on significant issues new developments and scientific findings that influence current research and practice in the ever growing field of school psychology Additional sections discuss building a cumulative knowledge base to better facilitate students academic social and personal competencies including the promotion of positive mental health and subjective well being



Getting the books **08 Ford Focus S Guide** now is not type of challenging means. You could not lonesome going subsequently ebook hoard or library or borrowing from your links to right to use them. This is an enormously easy means to specifically get lead by on-line. This online publication 08 Ford Focus S Guide can be one of the options to accompany you as soon as having new time.

It will not waste your time. allow me, the e-book will completely aerate you further matter to read. Just invest little time to door this on-line publication **08 Ford Focus S Guide** as well as evaluation them wherever you are now.

[https://legacy.tortoisemedia.com/results/publication/HomePages/2008\\_Volvo\\_Xc90\\_Service\\_Manual.pdf](https://legacy.tortoisemedia.com/results/publication/HomePages/2008_Volvo_Xc90_Service_Manual.pdf)

## **Table of Contents 08 Ford Focus S Guide**

1. Understanding the eBook 08 Ford Focus S Guide
  - The Rise of Digital Reading 08 Ford Focus S Guide
  - Advantages of eBooks Over Traditional Books
2. Identifying 08 Ford Focus S Guide
  - Exploring Different Genres
  - Considering Fiction vs. Non-Fiction
  - Determining Your Reading Goals
3. Choosing the Right eBook Platform
  - Popular eBook Platforms
  - Features to Look for in an 08 Ford Focus S Guide
  - User-Friendly Interface
4. Exploring eBook Recommendations from 08 Ford Focus S Guide
  - Personalized Recommendations
  - 08 Ford Focus S Guide User Reviews and Ratings
  - 08 Ford Focus S Guide and Bestseller Lists
5. Accessing 08 Ford Focus S Guide Free and Paid eBooks

- 08 Ford Focus S Guide Public Domain eBooks
  - 08 Ford Focus S Guide eBook Subscription Services
  - 08 Ford Focus S Guide Budget-Friendly Options
6. Navigating 08 Ford Focus S Guide eBook Formats
- ePub, PDF, MOBI, and More
  - 08 Ford Focus S Guide Compatibility with Devices
  - 08 Ford Focus S Guide Enhanced eBook Features
7. Enhancing Your Reading Experience
- Adjustable Fonts and Text Sizes of 08 Ford Focus S Guide
  - Highlighting and Note-Taking 08 Ford Focus S Guide
  - Interactive Elements 08 Ford Focus S Guide
8. Staying Engaged with 08 Ford Focus S Guide
- Joining Online Reading Communities
  - Participating in Virtual Book Clubs
  - Following Authors and Publishers 08 Ford Focus S Guide
9. Balancing eBooks and Physical Books 08 Ford Focus S Guide
- Benefits of a Digital Library
  - Creating a Diverse Reading Collection 08 Ford Focus S Guide
10. Overcoming Reading Challenges
- Dealing with Digital Eye Strain
  - Minimizing Distractions
  - Managing Screen Time
11. Cultivating a Reading Routine 08 Ford Focus S Guide
- Setting Reading Goals 08 Ford Focus S Guide
  - Carving Out Dedicated Reading Time
12. Sourcing Reliable Information of 08 Ford Focus S Guide
- Fact-Checking eBook Content of 08 Ford Focus S Guide
  - Distinguishing Credible Sources
13. Promoting Lifelong Learning
- Utilizing eBooks for Skill Development

- Exploring Educational eBooks
- 14. Embracing eBook Trends
  - Integration of Multimedia Elements
  - Interactive and Gamified eBooks

### **08 Ford Focus S Guide Introduction**

08 Ford Focus S Guide Offers over 60,000 free eBooks, including many classics that are in the public domain. Open Library: Provides access to over 1 million free eBooks, including classic literature and contemporary works. 08 Ford Focus S Guide Offers a vast collection of books, some of which are available for free as PDF downloads, particularly older books in the public domain. 08 Ford Focus S Guide : This website hosts a vast collection of scientific articles, books, and textbooks. While it operates in a legal gray area due to copyright issues, its a popular resource for finding various publications. Internet Archive for 08 Ford Focus S Guide : Has an extensive collection of digital content, including books, articles, videos, and more. It has a massive library of free downloadable books. Free-eBooks 08 Ford Focus S Guide Offers a diverse range of free eBooks across various genres. 08 Ford Focus S Guide Focuses mainly on educational books, textbooks, and business books. It offers free PDF downloads for educational purposes. 08 Ford Focus S Guide Provides a large selection of free eBooks in different genres, which are available for download in various formats, including PDF. Finding specific 08 Ford Focus S Guide, especially related to 08 Ford Focus S Guide, might be challenging as theyre often artistic creations rather than practical blueprints. However, you can explore the following steps to search for or create your own Online Searches: Look for websites, forums, or blogs dedicated to 08 Ford Focus S Guide, Sometimes enthusiasts share their designs or concepts in PDF format. Books and Magazines Some 08 Ford Focus S Guide books or magazines might include. Look for these in online stores or libraries. Remember that while 08 Ford Focus S Guide, sharing copyrighted material without permission is not legal. Always ensure youre either creating your own or obtaining them from legitimate sources that allow sharing and downloading. Library Check if your local library offers eBook lending services. Many libraries have digital catalogs where you can borrow 08 Ford Focus S Guide eBooks for free, including popular titles. Online Retailers: Websites like Amazon, Google Books, or Apple Books often sell eBooks. Sometimes, authors or publishers offer promotions or free periods for certain books. Authors Website Occasionally, authors provide excerpts or short stories for free on their websites. While this might not be the 08 Ford Focus S Guide full book , it can give you a taste of the authors writing style. Subscription Services Platforms like Kindle Unlimited or Scribd offer subscription-based access to a wide range of 08 Ford Focus S Guide eBooks, including some popular titles.

**FAQs About 08 Ford Focus S Guide Books**

**What is a 08 Ford Focus S Guide PDF?** A PDF (Portable Document Format) is a file format developed by Adobe that preserves the layout and formatting of a document, regardless of the software, hardware, or operating system used to view or print it. **How do I create a 08 Ford Focus S Guide PDF?** There are several ways to create a PDF: Use software like Adobe Acrobat, Microsoft Word, or Google Docs, which often have built-in PDF creation tools. Print to PDF: Many applications and operating systems have a "Print to PDF" option that allows you to save a document as a PDF file instead of printing it on paper. Online converters: There are various online tools that can convert different file types to PDF. **How do I edit a 08 Ford Focus S Guide PDF?** Editing a PDF can be done with software like Adobe Acrobat, which allows direct editing of text, images, and other elements within the PDF. Some free tools, like PDFescape or Smallpdf, also offer basic editing capabilities. **How do I convert a 08 Ford Focus S Guide PDF to another file format?** There are multiple ways to convert a PDF to another format: Use online converters like Smallpdf, Zamzar, or Adobe Acrobat's export feature to convert PDFs to formats like Word, Excel, JPEG, etc. Software like Adobe Acrobat, Microsoft Word, or other PDF editors may have options to export or save PDFs in different formats. **How do I password-protect a 08 Ford Focus S Guide PDF?** Most PDF editing software allows you to add password protection. In Adobe Acrobat, for instance, you can go to "File" -> "Properties" -> "Security" to set a password to restrict access or editing capabilities. Are there any free alternatives to Adobe Acrobat for working with PDFs? Yes, there are many free alternatives for working with PDFs, such as: LibreOffice: Offers PDF editing features. PDFsam: Allows splitting, merging, and editing PDFs. Foxit Reader: Provides basic PDF viewing and editing capabilities. How do I compress a PDF file? You can use online tools like Smallpdf, ILovePDF, or desktop software like Adobe Acrobat to compress PDF files without significant quality loss. Compression reduces the file size, making it easier to share and download. Can I fill out forms in a PDF file? Yes, most PDF viewers/editors like Adobe Acrobat, Preview (on Mac), or various online tools allow you to fill out forms in PDF files by selecting text fields and entering information. Are there any restrictions when working with PDFs? Some PDFs might have restrictions set by their creator, such as password protection, editing restrictions, or print restrictions. Breaking these restrictions might require specific software or tools, which may or may not be legal depending on the circumstances and local laws.

**Find 08 Ford Focus S Guide :****2008 volvo xc90 service manual****2008 volkswagen city jetta owners manual****2008 range rover supercharged manual**

~~2008 toyota prius service manual~~

**2009 audi a3 heater hose manual**

~~2008 mazda 3 4 door owners manual~~

~~2009 acura tsx manual review~~

~~2008 scion xb manual~~

**2009 audi a3 gasket material manual**

~~2008 nissan altima hybrid factory service manual~~

~~2008 nissan frontier service engine soon light~~

~~2008 nissan altima sedan owners manual~~

**2008 suzuki boulevard c109rt manual**

~~2008 pontiac g8 technical service bulletins~~

~~2008 saab 93 infotainment manual~~

## 08 Ford Focus S Guide :

**ryobi outdoor p2600 user manual manualmachine com** - Dec 07 2022

web 18 volt hedge trimmer p2600 batteries and chargers sold separately your hedge trimmer has been engineered and manufactured to our high standard for dependability ease of operation and operator safety when properly cared for it will give you years of rugged trouble free performance

**ryobi p2600 operator s manual pdf download manualslib** - Aug 15 2023

web view and download ryobi p2600 operator s manual online 18 volt hedge trimmer p2600 trimmer pdf manual download

**ryobi p2600 18 volt hedge trimmer erplacementparts com** - Feb 09 2023

web 1 cutter blade assembly obsolete not available part number 3013214 discontinued 2 screw m4 x 16 mm obsolete not available part number 6613702 discontinued 3 handle assembly obsolete not available part number 20073006 discontinued 4 screw m4 x 100 mm obsolete not available part number 660131001 discontinued 5

*hp müşteri desteği yazılım ve sürücü İndirmeleri* - Dec 27 2021

web Şunun için en güncel sürücüleri yazılımı ve aygıt yazılımını indirin hp deskjet 2600 all in one yazıcı serisi bu site windows ve mac işletim sistemi için hp programlama ve yazıcı ürünlerinin doğru sürücülerini otomatik olarak tespit edebileceğiniz ve ücretsiz olarak indirebileceğiniz resmi hp sitesidir

**ridgid ryobi yedek parça 940303260 verİ etiketİ p2600** - May 12 2023

web ridgid ryobi yedek parça 940303260 verİ etiketİ p2600 amazon com tr bilgisayar

**ryobi p600 operator s manual pdf download manualslib** - Apr 30 2022

web ryobi p600 operator s manual pdf download manualslib manuals brands ryobi manuals trimmer p600 operator s manual ryobi p600 operator s manual 18 volt trimmer also see for p600 operator s manual 62 pages manual del operador 24 pages manuel d utilisation 22 pages 1 table of contents 2 3 4 5 6 7 8 9 10 11 12 13 14 15 16

**battery compatible with ryobi p2600 p2603 p271 p300 p301** - Nov 06 2022

web mar 4 2022 amazon com battery compatible with ryobi p2600 p2603 p271 p300 p301 p310 p3200 p3300 p3310 p340 p400 p410 p420 p430 p500 p501 p506 p510 p514 p520 p521 p522 p530 p540 p570 p600 p610 tools home improvement tools home improvement

**tp link tl wpa4220kit av600 powerline wi fi extender** - Jan 28 2022

web sep 27 2020 tl wpa4220kit av600 powerline wi fi ile evinizde yeni bir güvenli kablosuz ağ kurmak için aşağıdaki adımları izleyin tl wpa4220kit av600 powerline nı yönlendiricinin modemin kullanılabilir bir lan bağlantı noktasına portuna bağlayın tl wpa4220kit av600 powerline adaptörünüzü bir duvar prizine takın

**ryobi p2600 manuel du propriétaire manualzz** - Jul 02 2022

web introduction cet outil offre de nombreuses fonctions destinées à rendre son utilisation plus plaisante et satisfaisante lors de la conception de ce produit l accent a été mis sur la sécurité les performances et la fiabilité afin d en faire un outil facile à utiliser et à entretenir 2 3 2 Règles de Sécurité gÉnÉrales avertissement

**ryobi one 18v 22 in cordless battery hedge trimmer tool** - Aug 03 2022

web the powerful motor provides 3 000 strokes per minute for efficient and effortless hedge bush and shrub trimming enjoy up to 35 minutes of runtime using an 18v one 1 5ah lithium battery easily tackle difficult hedges and thick branches with 22

**ryobi p2600 trimmer operator s manual guidessimo com** - Oct 05 2022

web jun 13 2023 ryobi p2600 trimmer pdf operator s manual updated saturday 8th of april 2023 04 16 19 am rating 4 1 rated by 15 users compatible devices rbc30sesa ry13016 rlt3025f rct2800ad 225rd rht450x abclt04g rlt1830h15 recommended documentation

**vanon p100 4000mah 18v replacement for ryobi 18v battery 2pack ryobi** - Mar 30 2022

web about this item battery specification 2 pack voltage 18v capacity 4 0ah type ni mh replacement for ryobi 18v battery offers long lasting performance and durability perfect compatibility compatible with replacement battery for ryobi abp1801 abp1803 bpp 1813 bpp 1815 bpp 1817 bpp 1817 2 bpp 1817m bpp 1820

**kompatibelt med ryobi p2600 18v 4000mah kjöp her** - Jun 01 2022

web kompatibelt med ryobi p2600 18v 4000mah kr 769 på lager for umiddelbar levering legg i handlekurven fast frakt 49 kr opptil 12 måneders garanti hurtig leveranse

*ryobi p2600 18 volt hedge trimmer partwarehouse com* - Jan 08 2023

web ryobi p2600 xx p2600 only operator s manual 960930102 p2600 p2600a operator s manual 960009394 hm 983000846 xx ni cd li ion charger 140501001 140501005 hm p113 xx ni cd charger 1423701 140237021 140237023 hm p110 xx li ion battery pack 130429001 130429002 hm p104 xx ni cd battery pack 130224028 hm p100 xx

**ryobi p2600a operator s manual pdf download manualslib** - Apr 11 2023

web view and download ryobi p2600a operator s manual online 18 volt hedge trimmer p2600a trimmer pdf manual download also for p2600

ryobi p2600 manuals manualslib - Jun 13 2023

web ryobi p2600 manuals manualslib ryobi p2600 manuals manuals and user guides for ryobi p2600 we have 2 ryobi p2600 manuals available for free pdf download operator s manual ryobi p2600 operator s manual 18 pages 18 volt hedge trimmer brand ryobi category trimmer size 1 64 mb table of contents 2 table of contents

**tp link archer vr2600 fiyatları cimri com** - Feb 26 2022

web tp link archer vr2600 fiyatları ve özelliklerini karşılaştır kategori marka ayrıştırması ile en uygun tp link archer vr2600 fiyat avantajını yakala cimri com da senin için 8 adet tp link archer vr2600 ürünü bulduk tp link archer vr2600 kategorisinde en favori router modem ve diğer kategorilerinden birini terciplendirip filtre seçimleriyle birlikte tp link

18v one hedge trimmer ryobi tools - Mar 10 2023

web nov 29 2018 the ryobi one 18v hedge trimmer work with all tools and batteries in the one system featuring 18 in dual action blades for reduced vibrations and user fatigue the ryobi one 18v hedge trimmer easily maintains shrubs and hedges the 18v cordless hedge trimmer is recommended for up to 1 3 acre and for growth up to 3 8

**ryobi p2660 18v lithium hedge trimmer 22 amazon com** - Jul 14 2023

web ryobi one 18v 22 in cordless battery hedge trimmer tool only the ryobi 22 in 18v cordless hedge trimmer is ideal for any hedge maintenance around the house the one hedge trimmer redefines the 18v category by delivering the power and performance you d expect from higher voltage lines while its lightweight compact design makes it

**ryobi p2600 cordless tool battery batteries plus** - Sep 04 2022

web find the best ryobi p2600 cordless tool battery from batteries plus bulbs shop traditional and lithium ion batteries from top brands for all your power tools

accounting grade 12 questions nsc past papers and memos november - Mar 21 2022

web jul 21 2021 grade 12 november 2017 national senior certificate grade 12 instructions and information read the following instructions carefully and follow them precisely answer all the questions a special answer book is provided in which to answer all the questions show all workings to earn part marks you may

past matric exam papers accounting life news24 - Jun 04 2023

web oct 14 2016 2013 accounting p1 memorandum 2013 answer book 2012 november 2012 accounting p1 2012 accounting p1 memorandum 2012 answer book 2012 february march 2012 accounting p1 2012 accounting p1 memorandum 2012 answer book 2011 november 2011 accounting p1 2011 accounting p1

national senior certificate grade 12 - Nov 28 2022

web grade 12 accounting november 2011 memorandum marks 300 marking principles penalties for foreign items are applied only if the candidate is not losing marks elsewhere in the question for that item no penalty for misplaced item no double penalty applied

national senior certificate grade 12 national - Dec 30 2022

web feb 22 2017 12 be aware that some candidates provide valid alternatives beyond the memorandum 13 codes f foreign item p placement presentation this memorandum consists of 15 pages accounting november 2016 memorandum national senior certificate grade 12

**accounting grade 12 november 2012 memorandum pdf** - May 23 2022

web accounting grade 12 november 2012 memorandum downloaded from controlplane themintgaming com by guest john heidi 2012 nsc examinations processing customer and supplier documents on sage pastel balance sheet

**new era accounting grade 12 memo studylib net** - Sep 26 2022

web grade 12 review solutions memo on 30 june 2013 the last day of the accounting period a second provisional tax payment of nov 11 2012 grade 11 in cases where answers of previous questions must be used carried forward acid test ratio did not show an improvement 0 9 1 to 0 5 1 10 accounting memo

2022 nsc november past papers national department of basic - Feb 17 2022

web national curriculum statements grades r 12 national curriculum framework for children from birth to four isindebele sal p2 nov memo download isindebele sal p2 download isindebele fal p2 nov memo download isindebele fal p3 accounting title memo 1 afrikaans download memo 1 english download memo 2 afrikaans

**national senior certificate grade 12 national** - Sep 07 2023

web feb 5 2013 accounting november 2012 memorandum marking principles penalties for foreign items are applied only if the candidate is not losing marks elsewhere in the question for that item no foreign item penalty for misplaced item no double penalty applied full marks for correct answer if answer incorrect mark the

accounting grade 12 questions nsc exams past - Mar 01 2023

web mar 7 2022 grade 12 national senior certificate november 2020 instructions and information read the following instructions carefully and follow them precisely answer all the questions a special answer book is provided in which to



answer all the questions show all workings to achieve part marks you may use a

**2012 nsc examinations national department of basic education** - Oct 08 2023

web certification services learners teachers parents and guardians principals education districts sgb s researcher national office address 222 struben street pretoria call centre 0800 202 933 callcentre db e gov za switchboard 012 357 3000

certification certification db e gov za 012 357 4511 3 government departments provincial

[national senior certificate grade 12 national](#) - Jun 23 2022

web jan 28 2016 1 1 bank reconciliation and internal control 1 1 1 calculate the correct bank balance on 30 june 2015

**grade 12 nsc past papers and answers pdf 4 eafinder com** - Jul 05 2023

web grade 12 past papers november 2012 1 accounting 2 agricultural sciences 3 agricultural technology 4 agricultural management practices 5 business studies 6 computer applications technology 7 consumer studies 8 civil technology 9 dance studies 10 design 11 dramatic arts 12 economics 13 electrical technology 14

**accounting paper 2 grade 12 memorandum nsc** - Jan 31 2023

web mar 7 2022 technical sciences paper 1 grade 12 memorandum nsc exams past papers and memos november 2020

provide figures to prove that tello was correct about the effect this decision would have on the cost of the jackets direct material cost per unit increased from r180 to r360 by 100 by r180 it doubled

[accounting grade 12 past papers memo p1 p2 student portal](#) - May 03 2023

web jan 12 2020 accounting grade 12 question papers and memorandums 2020 paper 1 paper 2 and answer book pdf that is printable for nsc exams english afrikaans studentportal org za wp content uploads 2022 04 accounting grade 12 november 2021 memorandum paper 1 2 jpeg course provider organization

**accounting grade 12 memorandum nsc past papers and memos november** - Apr 02 2023

web jul 21 2021 grade 12 november 2017 national senior certificate memorandum marking principles unless otherwise stated in the marking guideline penalties for foreign items are applied only if the candidate is not losing marks elsewhere in the question for that item no penalty for misplaced item no double penalty

*accounting grade 12 memorandum nsc past papers and memos november* - Jul 25 2022

web nov 25 2021 accounting grade 12 november 2019 memorandum national senior certificate marking principles unless otherwise stated in the marking guidelines penalties for foreign items are applied only if the candidate is not losing marks elsewhere in the question for that item no penalty for misplaced item no

**accounting grade 12 past exam papers and memos** - Aug 06 2023

web welcome to the grade 12 accounting past exam paper page here you ll find a comprehensive range of grade 12 past year exam papers and memos ranging from 2023 to as far back as 2009 our collection will help you prepare for your upcoming

exams by familiarizing yourself with the exam format and identifying areas for improvement

**accounting grade 12 past paper 2014 memorandum pdf** - Aug 26 2022

web jan 6 2016 accounting grade 12 past paper 2014 memorandum download as a pdf or view online for free

*accounting paper 2 grade 12 memorandum nsc* - Oct 28 2022

web aug 30 2022 grade 12 november 2021 memorandum nsc examinations question 1 1 1 provide two documents that zig zag traders will need from potential debtors before they will be allowed to open accounts any two accept recognisable abbreviations identity document id salary advice slip proof of income proof of

*accounting grade 12 november 2012 memorandum download* - Apr 21 2022

web accounting grade 12 november 2012 memorandum is available in our book collection an online access to it is set as public so you can get it instantly our digital library hosts in multiple locations allowing you to get the most less latency time to download any of

*most expected viva voice questions for basic* - Sep 03 2022

web cannot voice travel signal longer travel distance longer distance 4 to increase the signal to noise ratio question 7 what is the difference between analog modulation and

**digital communication viva questions last moment tuitions** - May 31 2022

web analog and digital communication as a technology analog is the process of taking an audio or video signal the human voice and translating it into electronic pulses digital

**basic electronics questions for interviews viva voce and** - May 11 2023

web april 2 2021 at ravi teja electronics general students need to face some basic electronics questions whether they represent preparations for an interview button viva

*400 top digital logic design viva questions and answers* - Jan 27 2022

web viva voice questions digital electronic viva voice questions digital electronic most expected viva voice questions for basic electronics viva questions

*digital electronics viva voce pdf computer engineering scribd* - Dec 06 2022

web digital ic lab viva voice questions part seven staff in charge 1 karthik s 2 asha p s 1 how chance of metastable state failure can be reduced 2 what are the

*digital communication viva questions electronics and* - Feb 08 2023

web digital electronics viva voce docx free download as word doc doc docx pdf file pdf text file txt or read online for free

*digital electronics lab viva questions pdf logic gate scribd* - Mar 09 2023

web jan 30 2021 digital communication lab viva questions with answers 1 list down the major advantages and disadvantages

of analog communication techniques the major

**viva voce questions on communication systems pdf duplex** - Jul 01 2022

web here we have equipped the significant digital electronics interview questions and answers which will assist you in getting accomplishment in your interview top digital

*viva questions for digital electronics pdf scribd* - Nov 05 2022

web most expected viva voce questions for basic electronics lab this video is beneficial for b tech first year students

**model viva questions for digital electronics ggpbilaspur** - Jun 12 2023

web model viva questions for digital electronics common to et t cse iii sem title of the practical verify the truth table of logic gates and or not nand and nor gates

viva voce questions digital electronic george brown - Oct 24 2021

basic electronics questions for interviews viva voce and answers - Jul 13 2023

web april 2 2021 byravi teja electronics engineering students need to face some basic electronics questions whether they are preparing for an interview or viva voce so

**digital ic lab viva voce questions pdf scribd** - Oct 04 2022

web ade lab viva questions 1 what are the disadvantages of analog communication its not reliable noise effect is more on the signals power required for signal transmission also

**digital electronics viva model viva questions for** - Jan 07 2023

web viva questions for digital electronics free download as word doc doc docx pdf file pdf text file txt or read online for free scribd is the world s largest social

engineers digital electronics lab viva questions - Feb 25 2022

web viva voce questions digital electronic june 19th 2018 practical viva voce etic 252 instrumentation engineering lab etec 258 digital electronics lab 0 question no

*digital electronics lab exam viva questions pdf logic gate* - Aug 14 2023

web digital electronics viva questions and answers 1 define gates ans gates are the digital circuits which perform a specific type of logical operation 2 define ic ans ic

**top 20 digital electronics interview questions answers** - Apr 29 2022

web dec 5 2011 q 1 draw circuit diagram of half adder circuit q 2 draw circuit diagram of full adder circuit q 3 draw full adder circuit by using half adder circuit and minimum no of

*viva voce questions digital electronic book* - Sep 22 2021

*viva voice questions digital electronic orientation sutd edu sg* - Dec 26 2021

web apr 20 2023 this viva voice questions digital electronic but stop occurring in harmful downloads rather than enjoying a good pdf taking into consideration a cup of coffee in

**ade lab viva questions pdf digital electronics logic gate** - Aug 02 2022

web 6 state important properties of cdf ans 1 every cdf  $f_x$  is non decreasing and right continuous  $\lim_{x \rightarrow 0} f_x(x) = 0$  and  $\lim_{x \rightarrow 1} f_x(x) = 1$  2 for all real numbers  $a$  and

*viva voice questions digital electronic dream networkonair* - Nov 24 2021

web viva voice questions digital electronic right here we have countless books viva voice questions digital electronic and collections to check out we additionally present

**interview viva questions and answers on digital** - Apr 10 2023

web digital electronics lab viva questions viva questions q 1 what do you mean by logic gates q 2 what are the applications of logic gates q 3 what is truth

**300 top most edc lab viva questions and answers** - Mar 29 2022

web digital logic design viva questions 1 explain about setup time and hold time what will happen if there is setup time and hold time violation how to overcome this set up time is